

## Description

These energy meters combine highly accurate industrial-grade **split-core current transducers (CTs)** and precision microprocessor-based **metering electronics in a single package** for exceptional metering accuracy and reduced metering system installed cost.

The unique design and installer-friendly features of the energy meter greatly reduce the time and overall cost of installing an energy metering system. Split-core CTs with color-coded leads install very quickly, clamping directly to the electrical conductor and eliminating the need for mounting brackets. For excellent total system accuracies of 1% (from 2 to 100% of the CT current rating, e.g., 2 to 100 amps with 100 amp CTs), each meter is factory-matched and calibrated with quickly installed split-core CTs.

The meter automatically detects and compensates for phase reversal, eliminating CT load orientation concerns. The meter provides an extended input voltage range (120 to 480 VAC, auto-ranging), a pulse output for control systems, and a phase loss alarm output for equipment protection.

As a stand-alone unit, the high-resolution **backlit LCD display** allows clear readings under any lighting conditions to reduce the risk of misinterpretation. The backlighting can be disabled if desired. The meter display provides true RMS measurement as well as installation diagnostics.

When equipped with an **optional internal BACnet or Modbus communications board**, the energy meter can report (through an EIA-485 connection to a building automation system) up to 26 energy and power variables, including volts, amps, power factor, kW, kVAR, kVA, and kWh on various lines.



## Models and Accessories

Amps	One CT	Two CTs	Three CTs
100	H8163-0100-0-1	H8163-0100-0-2	H8163-0100-0-3
200	H8163-0200-1-1	H8163-0200-1-2	H8163-0200-1-3
300	H8163-0300-2-1	H8163-0300-2-2	H8163-0300-2-3
400		H8163-0400-3-2	H8163-0400-3-3
800		H8163-0800-3-2	H8163-0800-3-3
800			H8163-0800-4-3
1600			H8163-01600-4-3
2400			H8163-2400-4-3
Optional Communication Boards with EIA-485 Connections			
	BACnet	H8186-CB	
	Modbus	H8163-CB	

## Applications

Useful for a variety of monitoring and control applications, typical uses include real-time power monitoring via local display or via optional interface board to a control system, monitoring critical motors and circuits, controlling circuits and disabling faulted circuits (requires communications board), monitoring load trends and run times, and verifying lighting circuit loads.

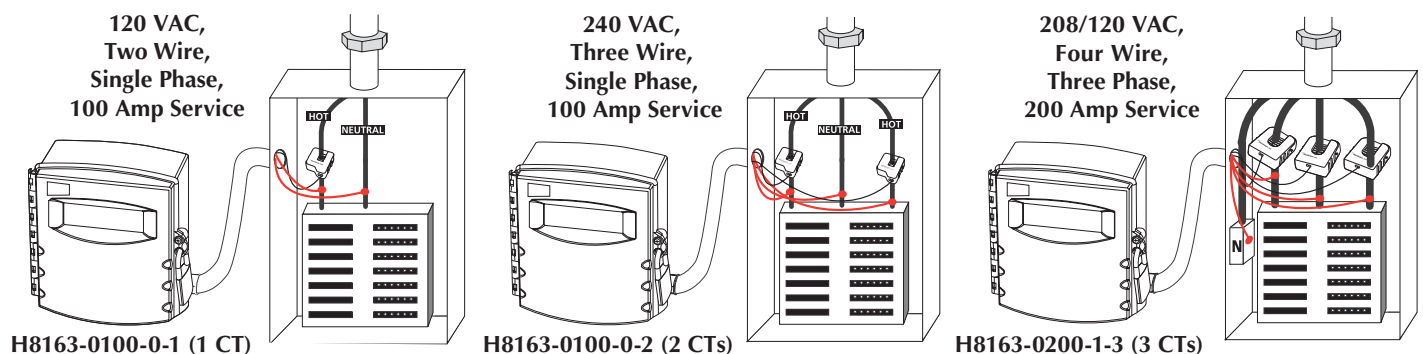

Specifications and design subject to change without notice.

## Dimensions

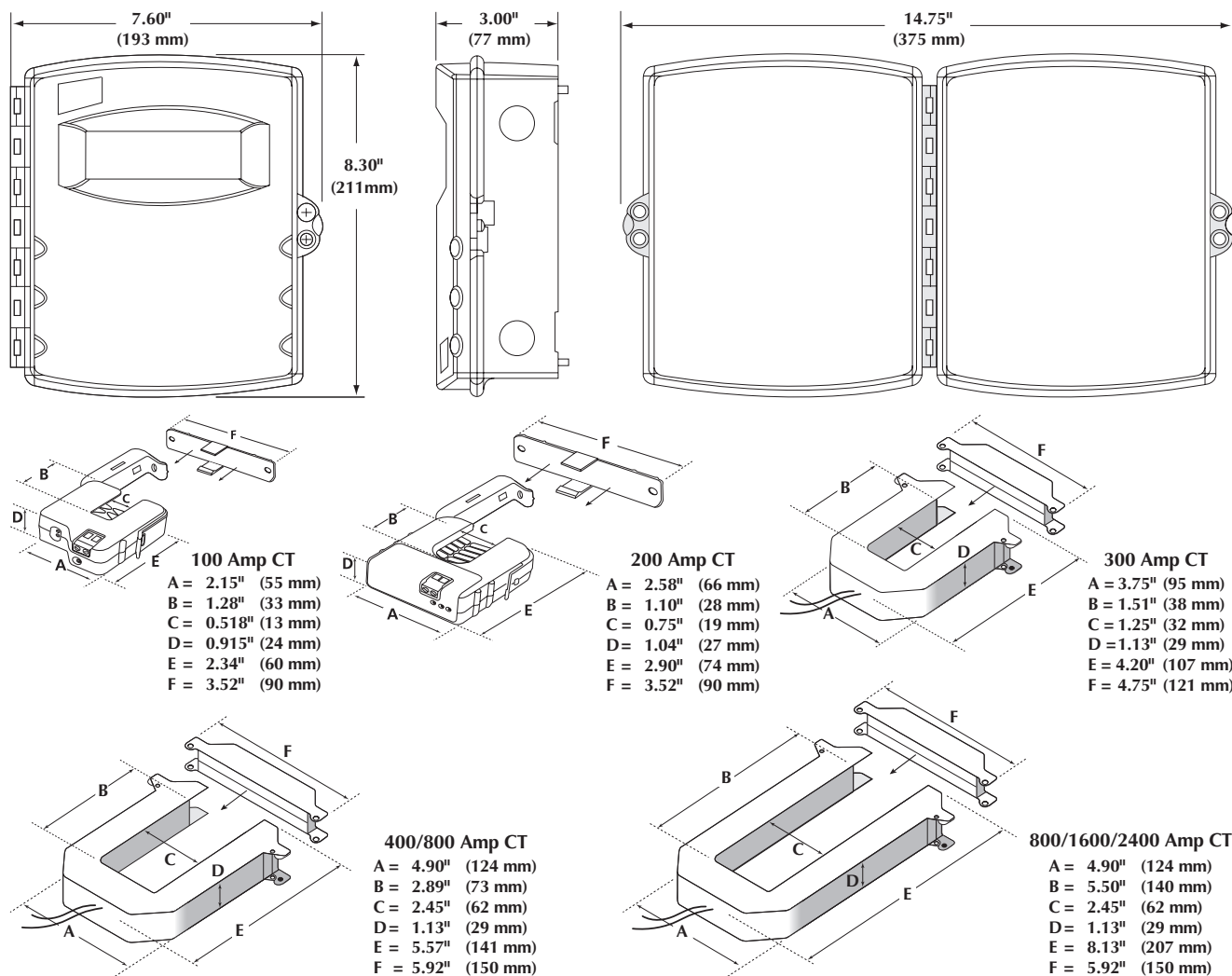

## Specifications

<b>LCD Display</b>	1.2" (31 mm) x 3.8" (97 mm) viewing area, 160 segments, back-lit with green LEDs	<b>Voltage Tolerance</b>	90 to 300 VAC line-to-neutral
<b>Electrical Services</b>	Service in which the phase A-N voltage is $\leq$ 300 VAC and the phase-to-phase voltage is $\leq$ 480 VAC nominal with neutral	<b>Pulse Output</b>	N.O., 100 mA @ 24 VAC/VDC
<b>Insulation Class</b>	600 VAC	<b>Pulse Rate</b>	0.10 (not supported at > 1600 A), 0.25 (not supported at > 2400 A), 0.50, or 1.00 kWh per pulse
<b>Internal Isolation</b>	2500 VAC	<b>Pulse Width</b>	200 msec. closed
<b>Frequency</b>	50/60 Hz	<b>Phase Loss Alarm</b>	N.C. output, opto-FET, 100 mA @ 24 VAC/VDC; fixed threshold 25% below any other phase, open as long as alarm persists
<b>Sample Rate</b>	1280 Hz	<b>Protection Class</b>	NEMA 1
<b>Temperature Range</b>			
<b>Storage</b>	-40 to 158° F (-40 to 70° C)		
<b>Operating</b>	32 to 122° F (0 to 50° C @ 0 to 95% RH non-condensing)		
<b>Systems Accuracy</b>	$\pm$ 1% of reading (at 2 to 100% of the CT's rated current)		
<b>Power Consumption</b>	50 VA		

**KMC Controls, Inc.**

19476 Industrial Drive, New Paris, IN 46553

574.831.5250

www.kmcccontrols.com; info@kmcccontrols.com